

# FMC E04

## SERIES E0413 | 39-160-03

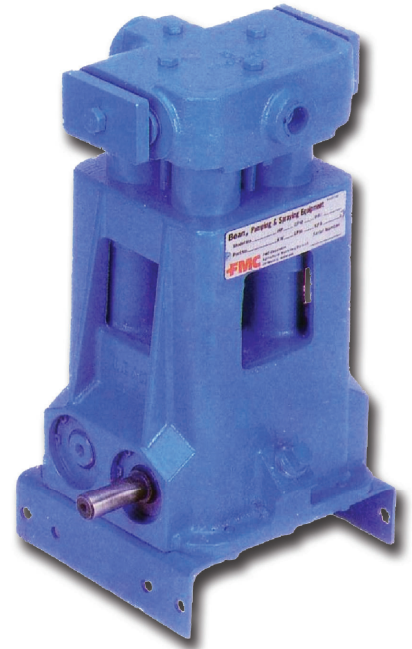

### Specifications:

- Flows to 19 gpm
- Pressures to 750 psi

### Features:

- Fluid end material of ductile iron
- Nitrided crankshaft resists corrosion
- Designed for easy, economical maintenance
- Cast iron pump case
- Special raised seat valves and hardened valve chamber available for abrasives

ITEM #	PART #	QTY	DESCRIPTION	ITEM #	PART #	QTY	DESCRIPTION
	39-160-03		E0413 FMC PUMP	20	39-1218743	4	SLEEVE, CROSSHEAD
1	39-1100064	2	HEX CAP SCREW ½"-13 X 1 ½" (PLATED STEEL)	21	39-1273545	1	CASE, PUMP (CAST IRON)
2	39-1255887	2	CLAMP, VALVE COVER (STEEL)	22	39-1105060	2	PLUG, OIL FILL (3/4" PIPE)
3	39-1219614	4	VALVE COVER (STEEL)	23	39-1216823	4	CROSSHEAD (CAST IRON)
4	568-213-90	12	"O" RING	24	39-1219650	4	WRIST PIN
5	39-1219610	8	VALVE CAGE (SS)	25	39-P509546	4	CONN. ROD ASM
6	39-5253499	8	VALVE DISC & SPRING ASM (SS)	26	39-P509560	1	CRANKSHAFT ASM, DRIVEN
7	39-5260142	8	SEAT, VALVE (SS)	27	39-P510882	1	CRANKSHAFT ASM, DRIVE
8	39-1101262	4	CAP SCREW, 3/8"-16 X 5"	28	39-P510834	4	BEARING INSERT, CONN ROD (PAIR)
9	39-1247208	1	VALVE CHAMBER (CAST IRON)	29	39-1118553	4	SNAP RING (N5000-244)
10	39-1109987	1	PIPE PLUG, ¼" GALV.	30	39-1101095	4	SEAL, OIL
11	39-1284516	4	CAP SCREW, 5/16"-18 X 1 ½" (SS)	31	39-1104508	1	BEARING (N.D. 5206)
12	39-5257986	4	PACKING WASHER	32	39-1104444	3	BEARING (N.D. 1206)
13	39-5257807	4	PACKING	33	39-P500359	2	OIL SLINGER
14	39-1282557	4	PACKING HOLDER	34	39-1273559	1	GASKET, PUMP BASE
15	568-015-90	4	"O" RING	35	39-1280633	1	MOUNTING BASE, PUMP
16	39-1269388	4	WASHER, UMBRELLA	36	39-1177455	12	WAVE LOCK WASHER, 3/8", S'PROOF
17	39-A91684	8	GASKET CYLINDER	37	39-1100008	12	CAP SCREW, 3/8" - 16 X ¾"
18	39-1241364	4	CYLINDER, CERAMIC	38	39-1101305	1	MAGNETIC DRAIN PLUG, ¼" PIPE
19	39-1279148	4	UMBRELLA	39	39-1250638	1	VALVE SEAT REMOVER



800.669.3542 | [info@timeltd.ca](mailto:info@timeltd.ca)

# FMC E04

## SERIES E0413 | 39-160-03

PERFORMANCE TABLE FMC E0413

PISTON DIAMETER (IN)	DISPLACEMENT (GAL/REV)	MAX PRESSURE (PSI)	PUMP CAPACITY (GPM) @ INPUT SPEED (RPM)				
			390	400	425	450	575
1.625	0.036	600	14.01	14.36	15.26	16.16	20.65

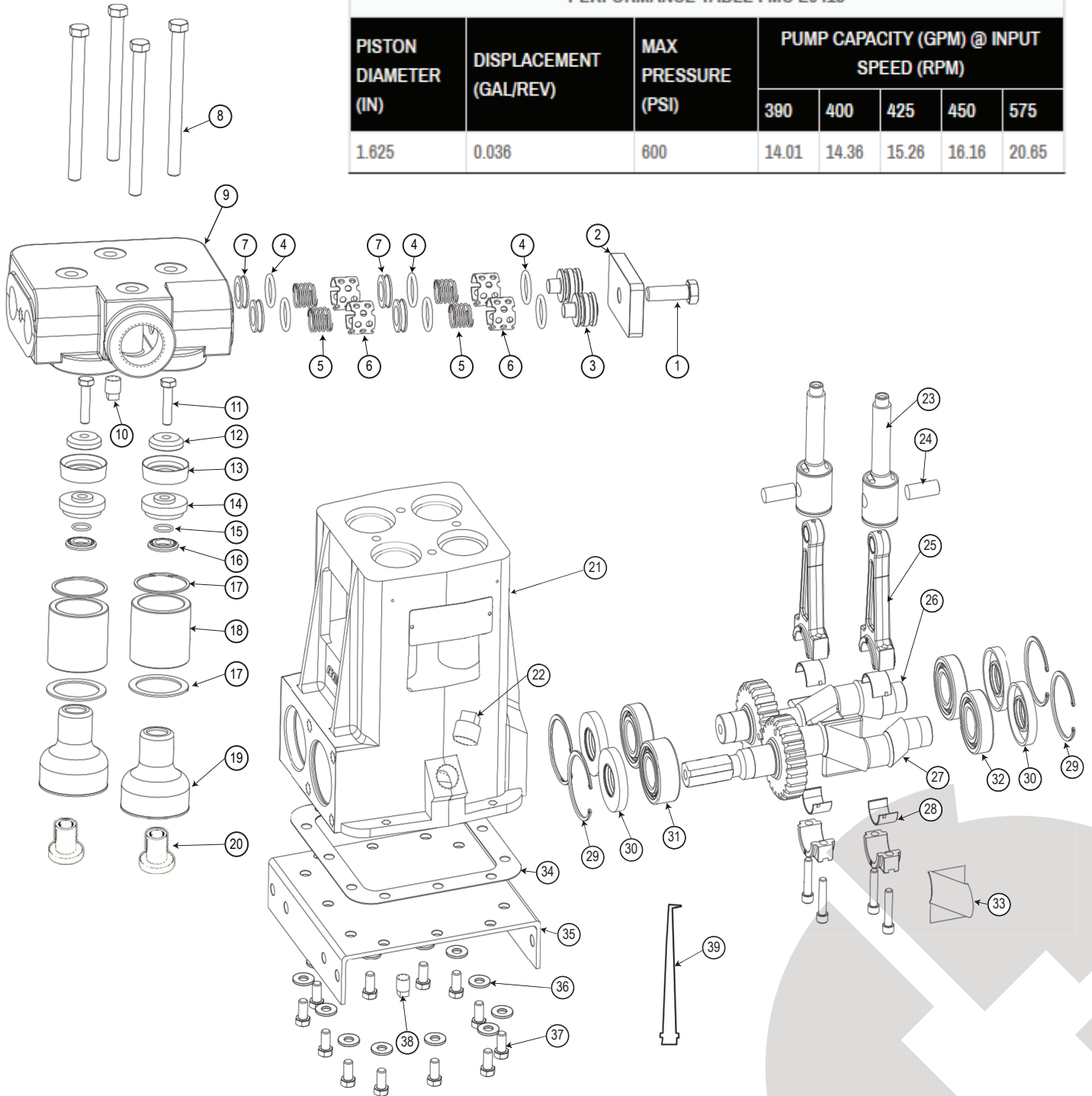

800.669.3542 | [info@timeltd.ca](mailto:info@timeltd.ca)

# FMC L09

## SERIES 420 | 39-160-00

### Specifications:

- Standard Suction Size: 1.50" NPT
- Standard Discharge Size: 1.00" NPT
- Pump Weight: 200 LBS
- 14 HP
- Flows to 28 GPM
- Pressures to 700 psi

### Features:

- Fluid end material of cast iron
- Pump can be easily repacked
- Ceramic cylinders
- Internal gear reduction in crankcase eliminates need for large sheaves
- Ball valves are available for pumping viscous materials such as drilling muds

ITEM #	PART #	QTY	DESCRIPTION	ITEM #	PART #	QTY	DESCRIPTION
	39-160-00		L09-420 FMC BEAN PUMP	28	39-5260537	1	PUMP CASE
	39-A5049		TOOL ASM PLUNGER NUT	29	39-1279065	1	GASKET - COVER
1	39-1255266	1	VALVE CHAMBER	30	39-1279063	1	BACK COVER
2	39-A5003M	3	VALVE COVER	31	39-1283600	3	PACKING NUT
3	39-1225327FMC	6	VALVE SEAT	32	39-1283601	3	PACKING NUT SLEEVE
	39-1225327HD	6	VALVE SEAT HEAVY DUTY	33	39-18710	3	CONNECTING ROD
4	39-1187738	6	15/16" SS BALL	34	39-P510831	3	ROD BEARING (PAIR)
	39-1101418	6	7/8" SS BALL	35	39-1279071	1	CRANKSHAFT & GEAR ASM
5	39-8495	3	PACKING HOLDER	36	39-1265098	1	PINION SHAFT
6	39-1207289	3	PACKING WASHER	37	39-1283603	9	ROD SEAL
7	39-A5016	3	PLUNGER NUT	38	39-1252594	5	SHIM
8	39-5260052	3	CUP PACKING - NITRILE	39	39-1225769	1	BEARING CAP
	39-A3434	3	CUP PACKING - NEOPRENE	40	39-1214260	1	COVER PLATE ASM
9	39-8309	3	HEX NUT 1/2 - 13 SS	41	GF610	3	LUBE FITTING
10	39-A5034M	3	PORCELAIN CYLINDER	42	39-1103470	3	SET SCREW 5/16 - 18 X 1/2
	39-1272060	3	CERAMIC CYLINDER	43	39-1104444	2	BALL BEARING
11	39-A5002M	3	CYLINDER HEAD COVER	44*	39-1281655	3	SEAL HOLDER
12	39-1280024	3	GASKET CYLINDER (COPPER)	45	0608B55ZG5	14	HHCS 3/8 -16 X 1/2
	39-1280024F	3	GASKET CYLINDER (FIBRE)	46	39-1100068	12	HHCS 3/8 -16 X 3/4
13	39-1280025	3	GASKET CYL. COVER(COPPER)	47	0812BHH1G5	2	HHCS 1/2 -13 X 3/4
	39-1280025F	3	GASKET CYL. COVER(FIBRE)	48	39-1187048	2	PLUG, 1/2
14	39-1280026	3	GASKET VALVE COVER(COPPER)	49	39-1121511	14	HEX NUT 1/2 -13
	39-1280026F	3	GASKET VALVE COVER(FIBRE)	50	39-1100243	3	LOCK WASHER
15	39-1250876	3	CROSSHEAD & ROD	51	568-014-90	3	"O" RING
16	39-1271415	3	CLAMP CYLINDER HEAD	52	39-1101242	2	CONE BEARING
17	39-1271716	3	CLAMP VALVE COVER	53	39-1177287	2	CUP BEARING
18	39-P548657	1	BEARING CAP (USED WITH OIL SEAL 39-P548658)	54*	39-A5046	3	BUSHING, CONNECTING ROD
18	39-P548658	1	OIL SEAL (FOR BEARING CAP 39-P548657)	55*	39-18743	6	BOLT, CONNECTING ROD
19	39-A5006	3	PIN	56	BI-109-H	1	PLUG 1" PIPE
20	39-A5009	2	STUD CYLINDER	57	BI-109-K	2	PLUG 1 - 1/2 PIPE
21	39-A5011	6	CYLINDER COVER STUD	58	39-1187039	1	PETCOCK 1/8 NPT
22	39-A5012	6	VALVE CLAMP STUD	59	39-1187577	1	KEY
23	39-1279064	2	BEARING HOUSING	60	39-1256641	1	DISC VALVE PARTS ASM
24	39-A5026	2	GASKET	<b>included in 60</b>			
25	39-A5025	2	GASKET	A	39-1245786	1	SEAT VALVE
26	39-A5054	1	OIL CAP	B	39-1250400	1	DISC & SPRING ASM
27	39-1283602	3	GASKET	C	39-5260958	1	VALVE SEAT
				D	39-1251822	1	SNAP RING

800.669.3542 | info@timeltd.ca

# FMC L09

## SERIES 420 | 39-160-00

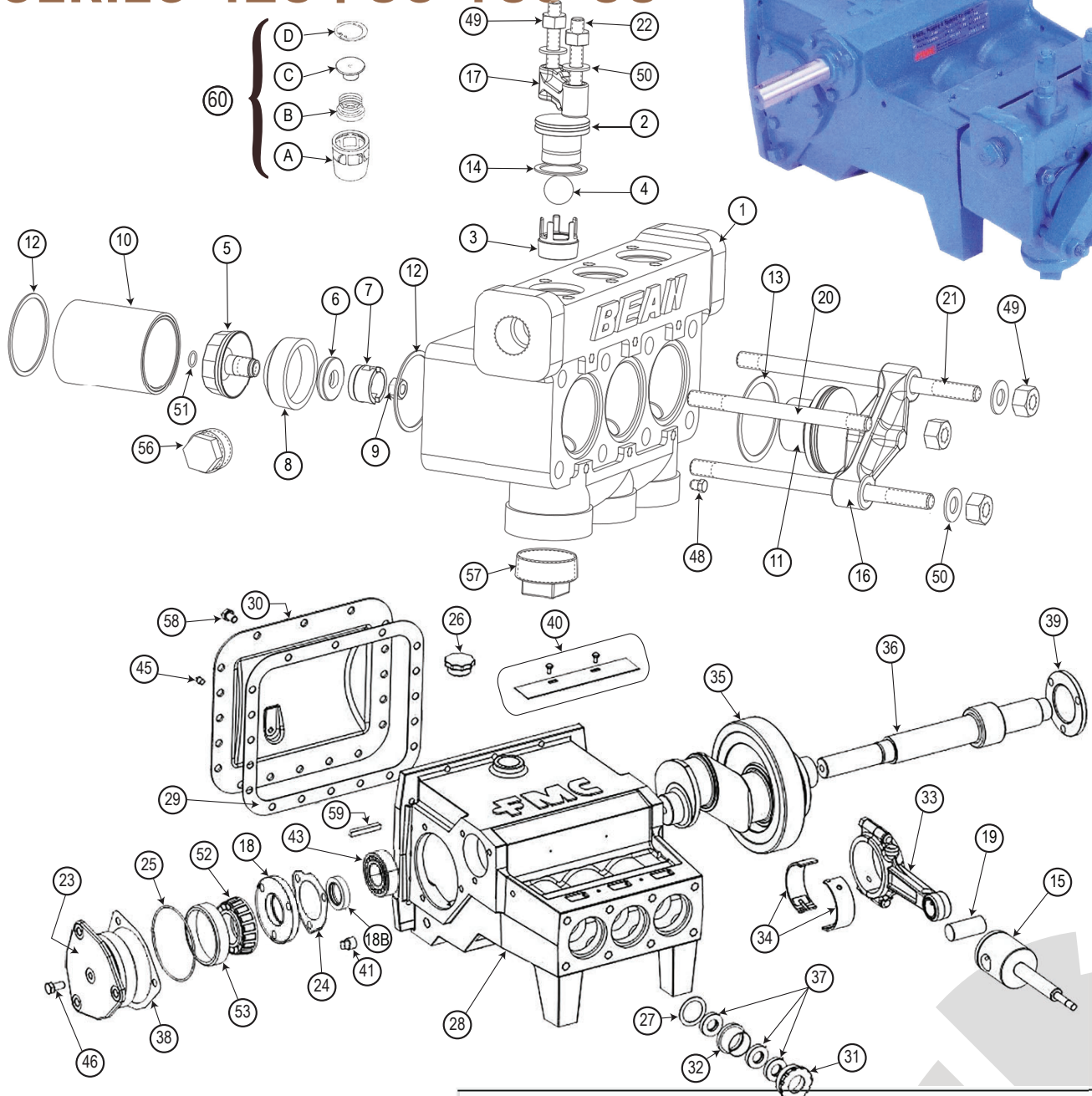
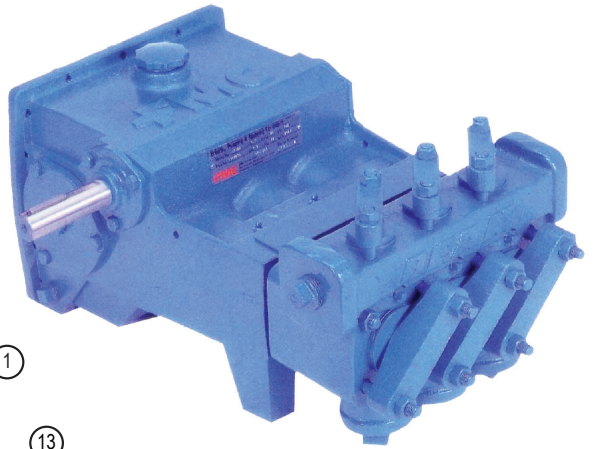

PERFORMANCE TABLE FMC L09-420

PISTON DIAMETER (IN)	DISPLACEMENT (GAL/REV)	MAX PRESSURE (PSI)	PUMP CAPACITY (GPM) @ INPUT SPEED (RPM)				
			390	625	700	750	890
2.750	0.0589	700	11.3	20.2	22.6	24.2	28.7



800.669.3542 | [info@timeltd.ca](mailto:info@timeltd.ca)

# FMC W11

## SERIES 435BCD | 39-160-04

ITEM #	PART #	QTY	DESCRIPTION	ITEM #	PART #	QTY	DESCRIPTION
	39-160-04		FMC W11-435BCD BEAN PUMP	31	39-1104349	1	KEY 3/8" X 2-1/2"
	39-A5049		TOOL ASM PLUNGER NUT	32	39-1187048	2	PIPE PLUG SQ HD 1/2 NPT CARBON STEEL
1	39-5257698	1	PUMP CASE	33	39-1187039	1	PETCOCK
2	39-1285094	1	CRANKSHAFT & GEAR	34	39-1284777	1	VALVE CHAMBER
3	39-5266814	3	CONNECTING ROD ASSEMBLY	35A	39-1284740	6	VALVE SEAT
4	39-P514965	3	ROD BEARING (PAIR)	35B	39-1284740HD	6	VALVE SEAT (SOLID CROWN DESIGN)
5	39-A91014	3	WRIST PIN	36	39-1101419	6	BALL, 1-1/8 DIA
6	39-1252939	3	CROSSHEAD ASM	37	39-1267586	3	CYLINDER-CERAMIC
7	39-3268369	3	PACKING HOLDER		39-A91664CLM	3	CYLINDER-PORCELAIN
	39-1266365	3	PACKING HOLDER (PRE 2014)	38	39-5260221	3	CUP PACKING - NITRILE
8	39-1177489	9	ROD SEAL		39-A268N	3	CUP PACKING - NEOPRENE
9	39-1248369	2	BEARING HOUSING	39	39-A91663	3	PACKING HOLDER
10	39-A91675	2	GASKET	40	39-1216753	3	PACKING WASHER
11	39-1252595	6	SHIM	41	39-1285112M	3	CYLINDER COVER
12	39-P508969	1	BACK COVER 18 HOLE	42	39-1279674	3	GASKET CYLINDER COVER - FIBER
	39-1250332	1	BACK COVER 16 HOLE (PRE 2014)		39-1247390	3	GASKET CYLINDER COVER - COPPER
13	39-P508966	1	GASKET, BACK COVER 18 HOLE	43	39-A80392	3	CYLINDER COVER CLAMP
	39-A91676	1	GASKET, BACK COVER 16 HOLE (PRE 2014)	44	39-1285113M	3	VALVE COVER
14	39-A5054	1	OIL CAP	45	39-1279675	3	GASKET VALVE COVER - FIBER
15	39-1177473	2	BEARING CONE		39-1247388	3	GASKET VALVE COVER - COPPER
			2.25 ID X 1.1875 LG	46	39-A80391	3	VALVE COVER CLAMP
16	39-1177474	2	BEARING CUP	47	39-1279676	6	GASKET CYLINDER - FIBER
			4.4375 OD X 1.1875 LG		39-1247389	6	GASKET CYLINDER - COPPER
17	39-P511596	1	PINION SHAFT	48*	39-1278104	6	VALVE DISC ASM (*CONSISTS OF ITEMS 48-1 TO 48-5)
	39-P513120	1	PINION SHAFT (DOUBLE SIDED)	48-1	39-1278054	6	SEAT, VALVE
18	39-P508916	1	PINION CAP	48-2	39-5277943	6	DISC
19	39-5257338	1	PINION BEARING CAP (USED WITH OIL SEAL 5257339)	48-3	39-1283377	6	SPRING
20	39-P511746	2	BEARING, SPHERICAL ROLLER	48-4	39-1283376	6	WASHER
20	39-1272558	2	BALL BEARING (PRE 2014)	48-5	39-1101229	6	RETAINING RING
21	39-A91674	2	GASKET	49	568-014-90	3	"O" RING
22	39-5257339	1	OIL SEAL (FOR PINION BEARING CAP 5257338)	50	39-A5016	3	PLUNGER NUT 3/4-16 UNF
23	39-1266323	3	PACKING NUT	51	08NHZGR5	6	HEX NUT1/2-13 UNC-2B
24	39-3268418	3	PACKING GASKET	52	10NHZ	8	HEX NUT 5/8-11 UNC-2B
	39-19510	3	PACKING WASHER (PRE 2014)	53	39-8309	3	NUT, HEX 1/2-13 UNC
25	39-1103470	6	SET SCREW 5/16"	54	BI-109-J	1	PLUG; 1-1/4"
26	39-5260567	1	INSPECTION PLATE	55	BI-109-A	6	PIPE PLUG; HEX HEAD 1/8-27 NPT
27	568-252-90	2	O-RING	56	BI-109-M	2	SQUARE HEAD PLUG
28	0408BHHZG5	2	CAP SCREW, HX HD, 1/4-20 UNC2A X 0.5 LG	57	39-A5076	6	STUD 1/2-13UNC-2A X 3.5 LONG
29	0816BHHZG5	12	CAP SCREW 1/2"	58	39-A91672	2	STUD 5/8-11 UNC-2A X 7.88 LONG
30	0812BHHZG5	20	CAP SCREW, HX HD,	59A	39-1279602	6	STUD 5/8-11 UNC-2A X 10 LONG
			1/2-13 UNC2A X 0.75 LG	59B	39-P544895	6	STUD 5/8-11 UNC-2A X 10.5 LONG (FOR OLDER MODEL PUMPS)
				60	08WLZ	6	WASHER, FLAT 1/2 TYPE A
				61	10WLZ	6	WASHER, FLAT 5/8 TYPE A

### Specifications:

- Standard Suction Size: 1.50" NPT
- Standard Discharge Size: 1.00" NPT
- Pump Weight: 200 LBS
- 14 HP
- Flows to 28 GPM
- Pressures to 1000 psi

### Features:

- Fluid end material of cast iron
- Pump can be easily repacked
- Ceramic cylinders
- Internal gear reduction in crankcase eliminates need for large sheaves
- Ball valves are available for pumping viscous materials such as drilling muds



800.669.3542 | info@timeltd.ca

# FMC W11

SERIES 435BCD | 39-160-04

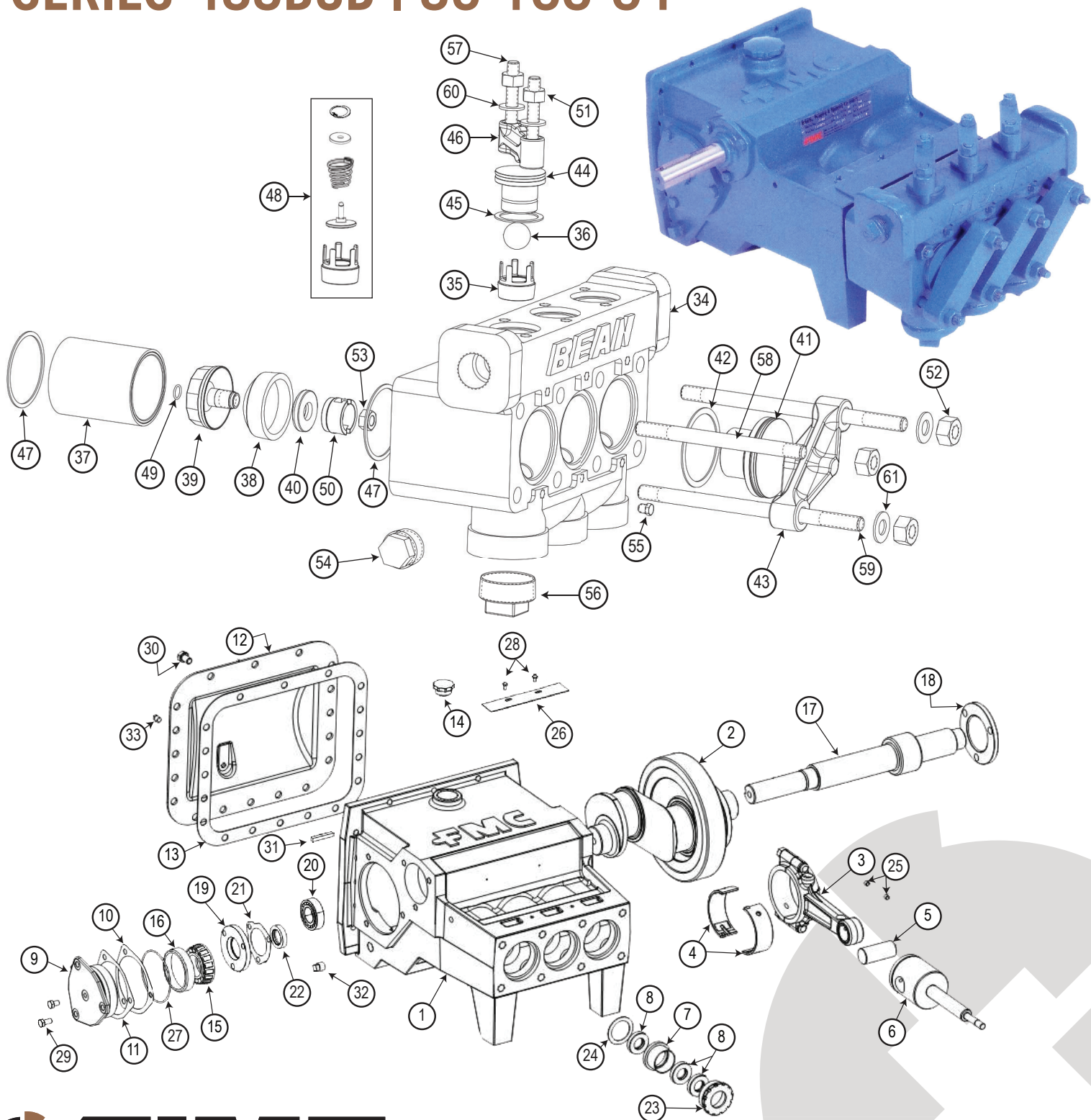

# FMC L1122D

## SERIES 470 | 39-160-08

ITEM #	PART #	QTY	DESCRIPTION	ITEM #	PART #	QTY	DESCRIPTION
	39-160-08		FMC L11-470 BEAN PUMP	33	39-1266365	3	SLEEVE, PACKING NUT
	39-A5049		TOOL ASM PLUNGER NUT	34	39-1266323	3	PACKING NUT
1	39-5257698	1	PUMP CASE	35	39-A5054	1	CAP, OIL
2	39-1285094	1	CRANKSHAFT	36	39-1187048	2	PLUG, ½ PIPE, MAGNETIC
3	39-5266814	3	CONNECTING ROD ASSEMBLY	37	39-5251859	6	STUD, LONG 5/8 X 12-1/4
4	39-P514965	3	BEARING INSERT	38	39-1279676	6	GASKET CYL., FIBER
5	39-9226	3	BUSHING, CONNECTING ROD		39-1247389	6	GASKET CYL., COPPER
8	39-1252939	3	CROSSHEAD & ROD ASM	39	39-1267586	3	CYL., CERAMIC
9	39-1103470	6	SET SCREW 5-16-18X 5/16		39-A91664CLM	3	CYL., PORCELAIN
10	39-A91014	3	WRIST PIN	40	39-A91663	3	CUP
11	568-014-90	3	"O" RING	41	39-5260221	3	CYL. PACKING, ABRASIVE
12	39-1177473	2	CONE, BEARING	42	39-1216753	3	WASHER
13	39-1177474	2	CUP BEARING	43	39-A5016	3	NUT, PLUNGER
14	39-A91675	2	GASKET	44	39-8309	3	NUT, SPECIAL
15	39-1252595	A/R	SHIM	45	39-5257262	1	VALVE CHAMBER
16	39-1248369	2	HOUSING, CRANKSHAFT BEARING	46	39-5255419	6	DISC VALVE ASM
17	0420BHHZG5	12	CAPSCREW, HEX 1/4"-20 X 1-1/4" NC ZP GR5	47*	39-5253514	6	SEAT, VALVE
				48*	39-5260847	6	VALVE
18	0812BHHZG5	18	CAPSCREW, HEX ½ -13 X ¾	49*	39-320153	6	RETAINING RING
				50*	39-5260848	6	WASHER
19	39-P511596	1	PINION SHAFT	51*	39-1283377	6	SPRING
	39-P513120	1	PINION SHAFT (DOUBLE SIDED)	52	568-233-90	3	CYL. HEAD "O" RING
20	39-1272558	2	BALL BEARING	53	39-1283531	3	CYL. COVER
21	39-A91674	2	GASKET	54	39-A80392	3	CLAMP CYL. HEAD
22	39-P508916	1	PINION CAP	55	39-1248349	2	STUD, 5/8 X 9-1/2
23	39-1266789	1	CAP, PINION BEARING	56	10NHZ	8	NUT, HEX 5/8 -11
24	39-A91676	1	GASKET, COVER	57	568-227-90	3	VALVE COVER "O" RING
25	39-1250332	1	COVER, PLATE	58	39-1283530	3	VALVE COVER
26	39-1187039	1	PETCOCK	59	39-1247716	3	CLAMP, VALVE COVER
29	39-5260567	1	INSPECTION PLATE	60	39-1248372	6	STUD, ½ X 4
30	39-1100759	3	LUBE FITTING, 1/8 C/Z	61	08NHZGR5	6	NUT, HEX ½ - 13
31	39-19510	3	WASHER, PACKING				
32	39-1177489	6	ROD SEAL				

### Specifications:

- Standard Suction Size: 2.50" NPT
- Standard Discharge Size: 1.25" NPT
- Pump Weight (Average): 460 lbs

### Features:

- Fluid end material of ductile iron
- Pump can be easily repacked
- Ceramic cylinders
- Internal gear reduction in crankcase eliminates need for large sheaves
- Ball valves are available for pumping viscous materials such as drilling muds

PERFORMANCE TABLE FMC L11-470

PISTON DIAMETER (IN)	DISPLACEMENT (GAL/REV)	MAX PRESSURE (PSI)	PUMP CAPACITY (GPM) @ INPUT SPEED (RPM)				
			360	690	900	1050	1275
2.750	0.0589	1,000	21.2	40.7	53.0	61.9	75.1



800.669.3542 | info@timeltd.ca

# FMC L1122D

SERIES 470 | 39-160-08

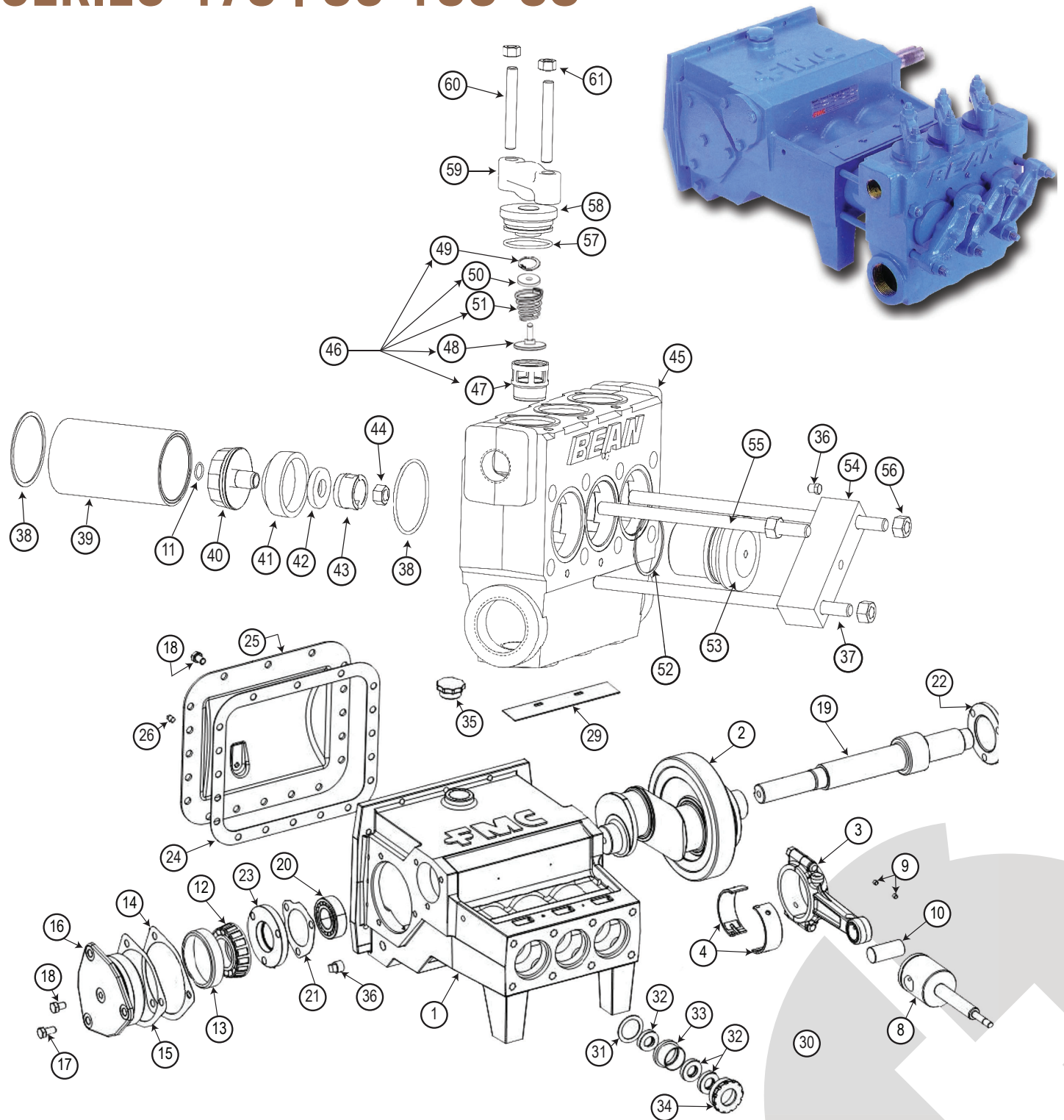

800.669.3542 | [info@timeltd.ca](mailto:info@timeltd.ca)